



# Barilla TRIC A On-Roof Installation

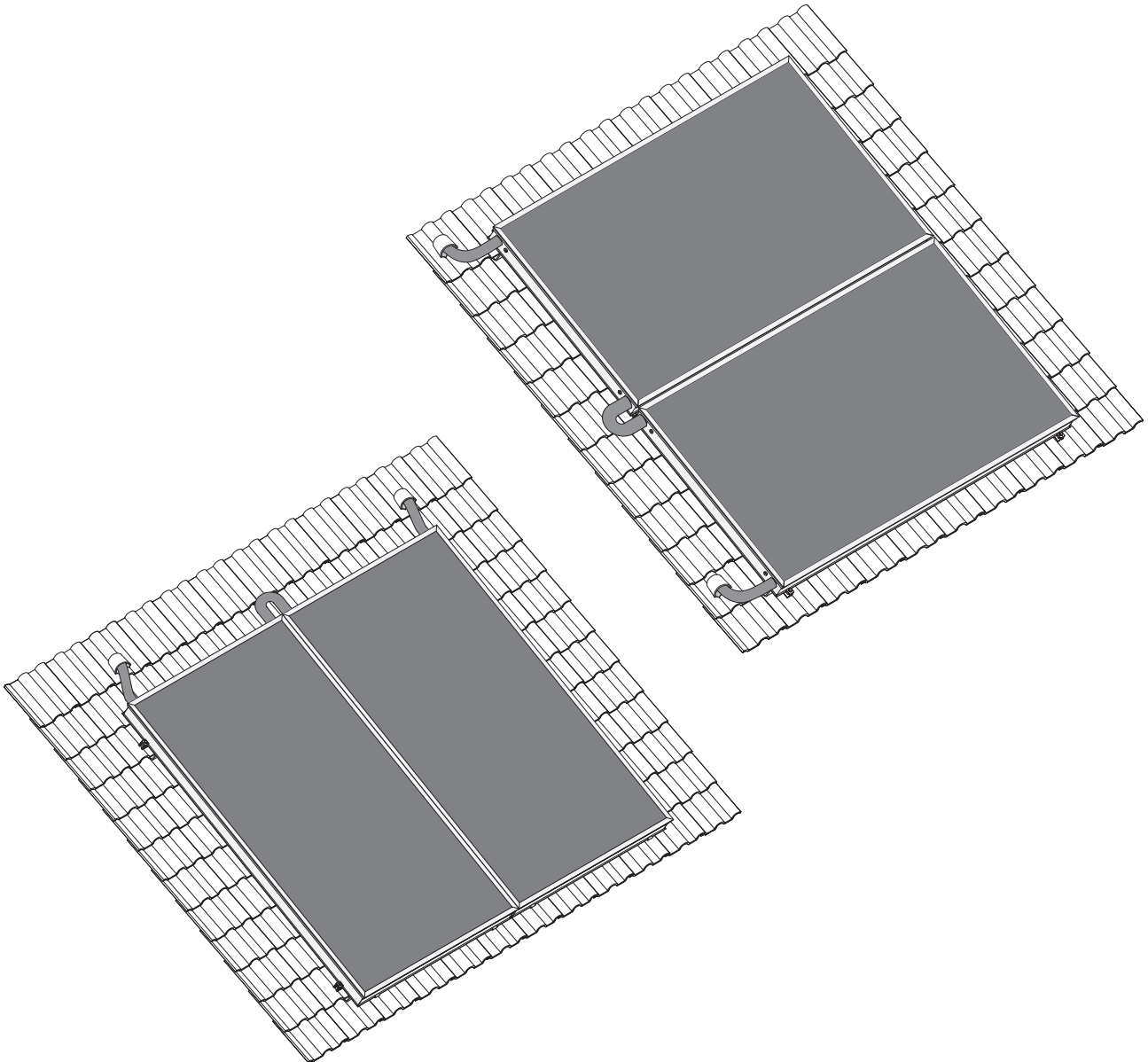

Figure 1 Vertical and horizontal on-roof installation

## Content

1. General Safety Notes . . . . .	2
2. Horizontal Installation . . . . .	4
3. Vertical Installation . . . . .	9
4. Sensor Installation . . . . .	14
5. Collector Connections. . . . .	15
6. Accessories . . . . .	16

# 1. General Safety Notes

## 1.1 Symbols

The following symbols are used throughout these instructions and must be adhered to:



DANGER of possibly serious personal injury



WARNING against material damage.



NOTE as additional information

## 1.2 Norms and Regulations

The standards and regulations applicable at the installation location must be adhered to. In absence of other regulations we recommend to follow the following norms:

### Thermal Solar Systems and Components

- EN 12976 and EN V 12977

### Electrical Work, Potential Equalization, Lightning Protection

- DIN EN 62305
- VDE 0185 part 305
- DIN VDE 0100 part 540
- VDE 190
- DIN 18382

(Other regulations may apply, depending on your region, country or territory.)

Especially the pipes in the lower parts of the building must be connected electrically conductive, conforming to standards. The collector installation must be professionally integrated with an existing or new lightning protection system.

### Snow and Wind Loads

Comply with local regulations and norms related to snow and wind loads, within the EU to EN 1991-1-4 (Wind Actions) and EN 1991-1-3 (Snow Loads). If you have questions related to structural conditions and planning, please contact our technical department for information. We offer comprehensive planning support on a project base.

### Work on Roofs

Make sure to observe country and territory regulations related to roof works and roof sealing standards as well as professional codes for plumbing work.

The installation process must reflect the on-site conditions as well as applicable rules, regulations and accident prevention procedures. Installers must be qualified and - where applicable - licensed to work on roofs.

## 1.3 Qualification of the Installer

Setup, installation and proper commissioning of the solar installation must be carried out by authorized professionals. Non-compliance renders the warranty void.

## 1.4 Intended Use and Application

### Proper Outdoor Storage of Collectors

Remove protective film, and lay down collectors with glass pane up. Avoid direct ground contact (e.g. underlay square timber). Avoid scratches on glass panes by using spacers between collectors (e.g. wooden laths). When leaning collectors against walls or similar, use a minimum inclination of 15° and apply spacers. Do not use cardboard as underliner. If incorrectly stored, humidity can enter the collectors through the air vents. Storing collectors in plastic film package can damage the glass surface (see figure 2).



### Scope and Limitations of Application

The collector is intended for the application in solar thermal installations for hot water preparation and space heating support. As operating mediums water (attention - risk of freezing!) or an appropriate water-glycol mixture can be used in a closed circuit. Operational conditions under-running the dew point within the collector for prolonged periods are not permitted! This can occur for example, when collectors are integrated in the brine circuit of a heat pump.



### Overheat Protection

For roof heating centrals and when 4 or more collectors with anti reflective glass are installed vertically, the "Technical Information Solar Thermal Systems - Setup, Commissioning and Maintenance" must be followed to avoid damage to the solar circuit.

### Preventing frost Damage

After pressure testing and flushing, collectors cannot be completely emptied. Make sure that no pure water remains in collector during risk of frost!



### Empty Collector on Roof

After being installed on the roof, unfilled collectors should not be exposed to the sun for more than a few days. Otherwise thermal stress on gaskets can result in damage. Alternatively postpone the installation of gaskets to just before filling the solar circuit.



### Maintenance

For maintenance notes and additional information about setup and operation of the collector field, please refer to the technical information "Solar Thermal Systems".

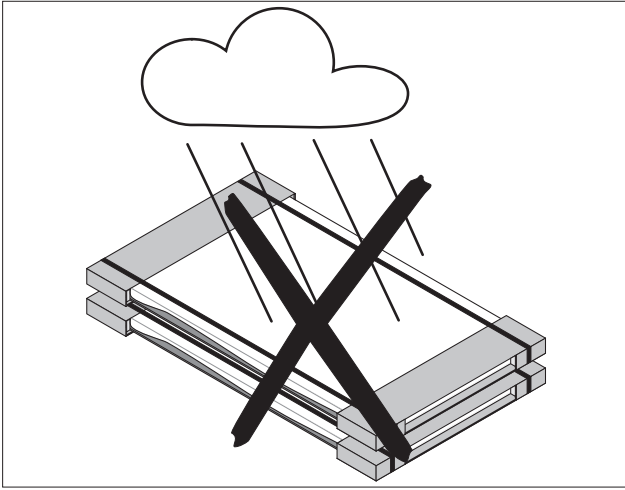

Figure 2 Do not expose collector covered with protective film to rain.

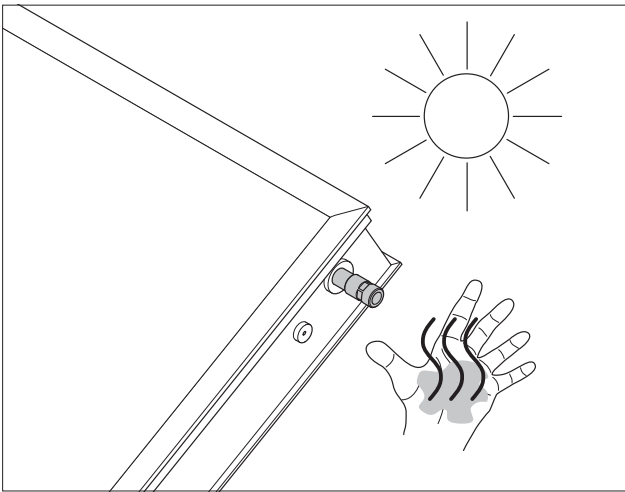

Figure 3 Collector connections heat up during solar irradiation.

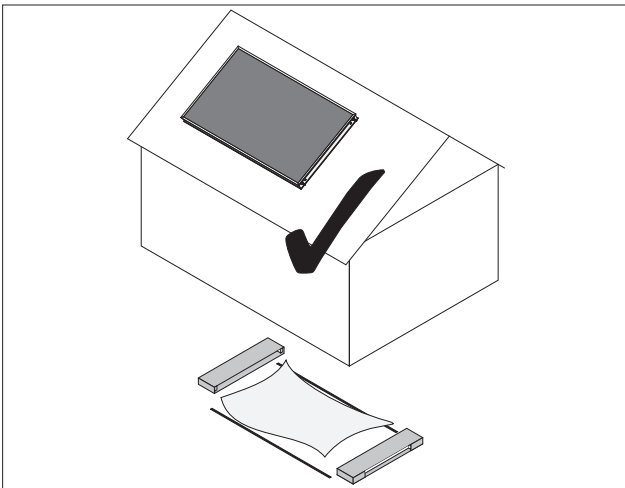

Figure 4 Remove glass protection film before installing collector!

## 1.5 Pre Installation Notes

- Risk of burns at collector connections as soon as uncovered collector is exposed to the sun (figure 3).
- Danger of open injuries when working with sharp edged metal sheets and components!
- Remove protective plastic caps from connections before collector is exposed to the sun. Risk of melting and damage to absorber!
- Remove glass protection PE-LD film before commencing installation work! (figure 4).



## 1.6 Recycling Note

At the end of the long operational lifetime, the valuable materials of the installation should be recycled in an environmentally sound manner. If recycling is not possible, Barilla will take the scrap material back.

## 2. Horizontal Installation

### 2.1 Scope of Supply

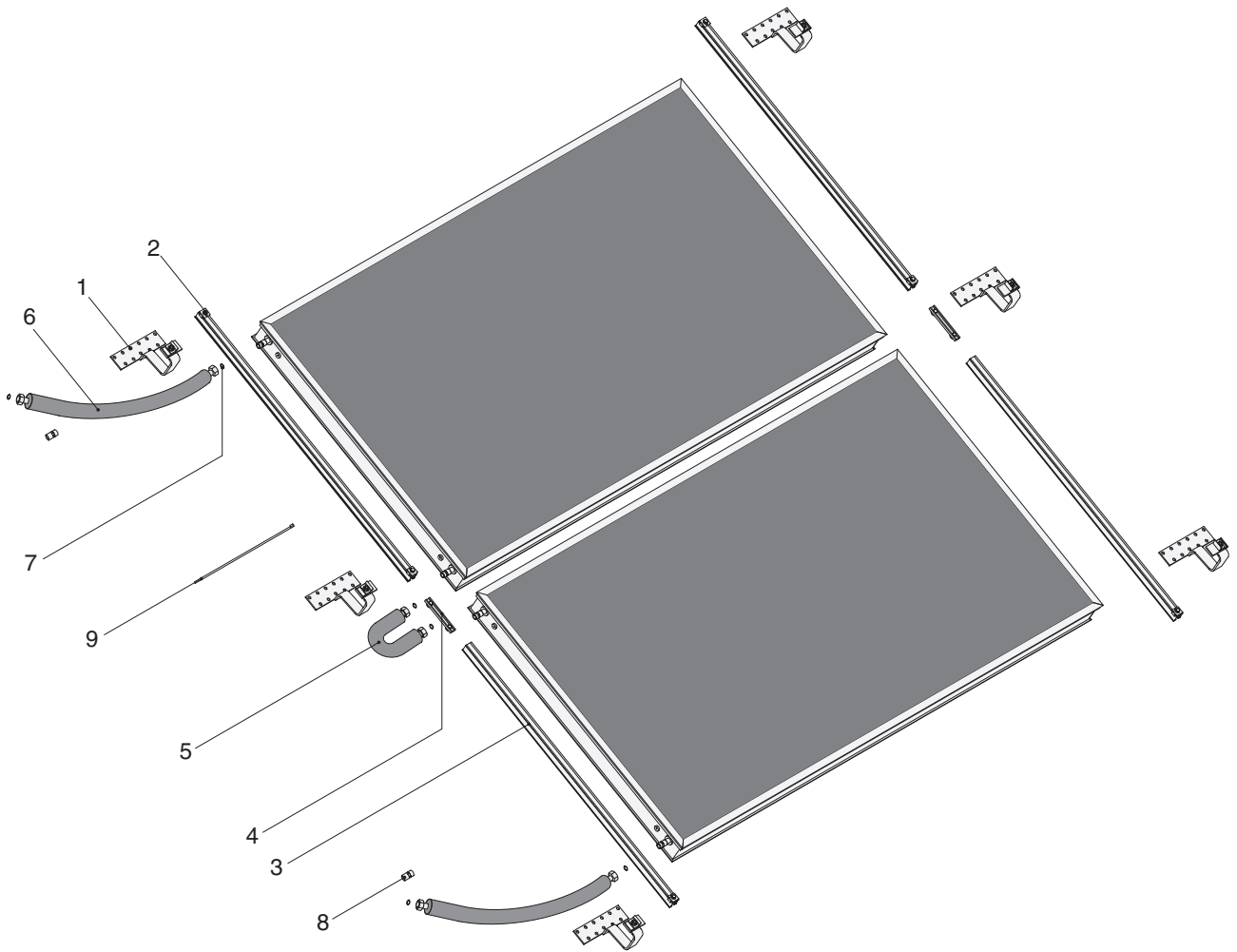

Figure 5 Basic set for on-roof installation (collectors are not included in delivery)

Table 1 Figure no.	Components: Basic Set for On-Roof Installation	Quantity
1	Roof bracket <sup>1</sup>	(6) <sup>2</sup>
2	Collector supporting rail 1202 mm, incl. 2 collector clamps	2
3	Collector supporting rail 1168 mm, incl. 1 collector clamp	2
4	Collector supporting rail connector	2
5	Collector interconnection hose, 250 mm length	1
6	Collector connection hose for solar circuit, 900 mm length	2
7	Gasket ½"	6
8	Adapter fitting ½" - 18 mm	2
9	Wire strap	1
	The included collector holders are not required for horizontal installation	(4)

<sup>1</sup> Not included in set; choose according to roofing type. <sup>2</sup> Required number depends on structural load calculation.

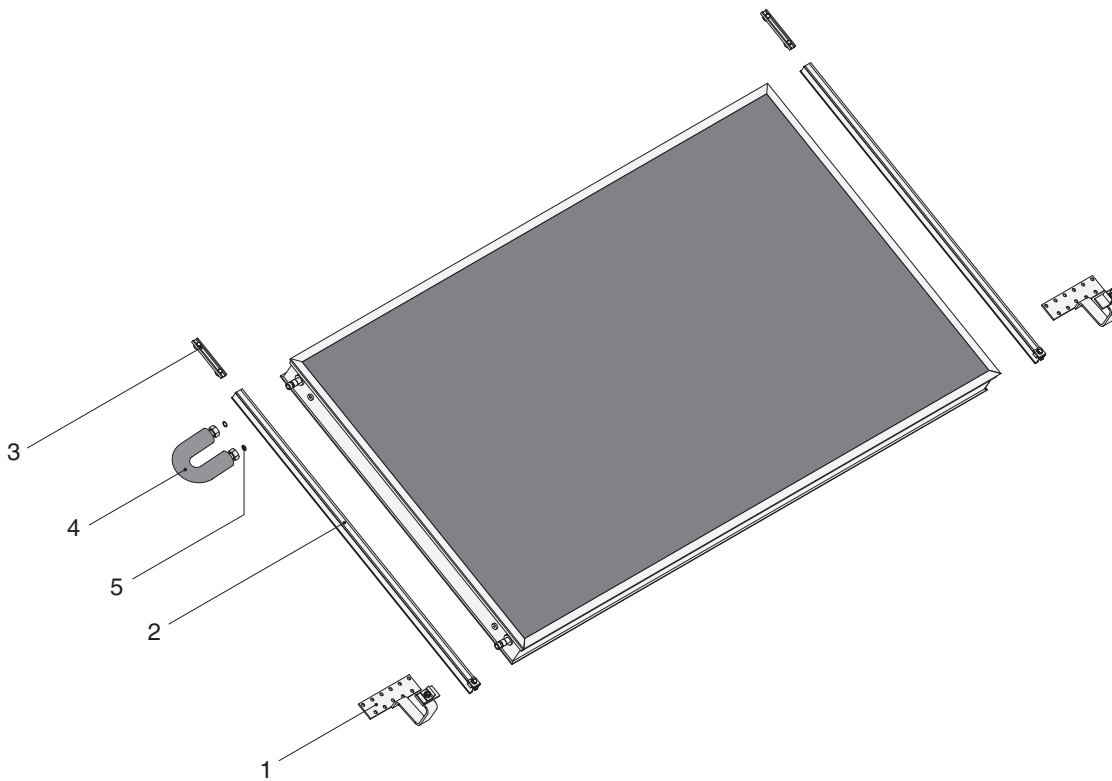

Figure 6 Extension set for on-roof installation (collectors are not included in delivery)

Table 2 Figure no.	Components: Extension Set for On-Roof Installation	Quantity
1	Roof bracket <sup>1</sup> (not included within the set)	(2) <sup>2</sup>
2	Collector supporting rail 1168 mm, incl. 1 collector clamp	2
3	Collector supporting rail connector	2
4	Collector interconnection hose, 250 mm length	1
5	Gasket ½"	2
	The included collector holders are not required for horizontal installation	(2)
<sup>1</sup> Not included in set; choose according to roofing type. <sup>2</sup> Required quantity depends on structural load calculation.		

## 2.2 Installation of Roof-Brackets

**i** The roof brackets shown in this manual are given as examples only. The actual type varies and depends on the roofing. For more information refer to the installation instructions included with the roof brackets.

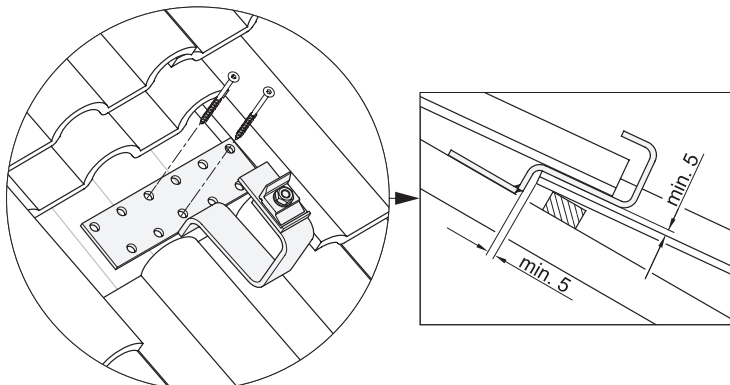
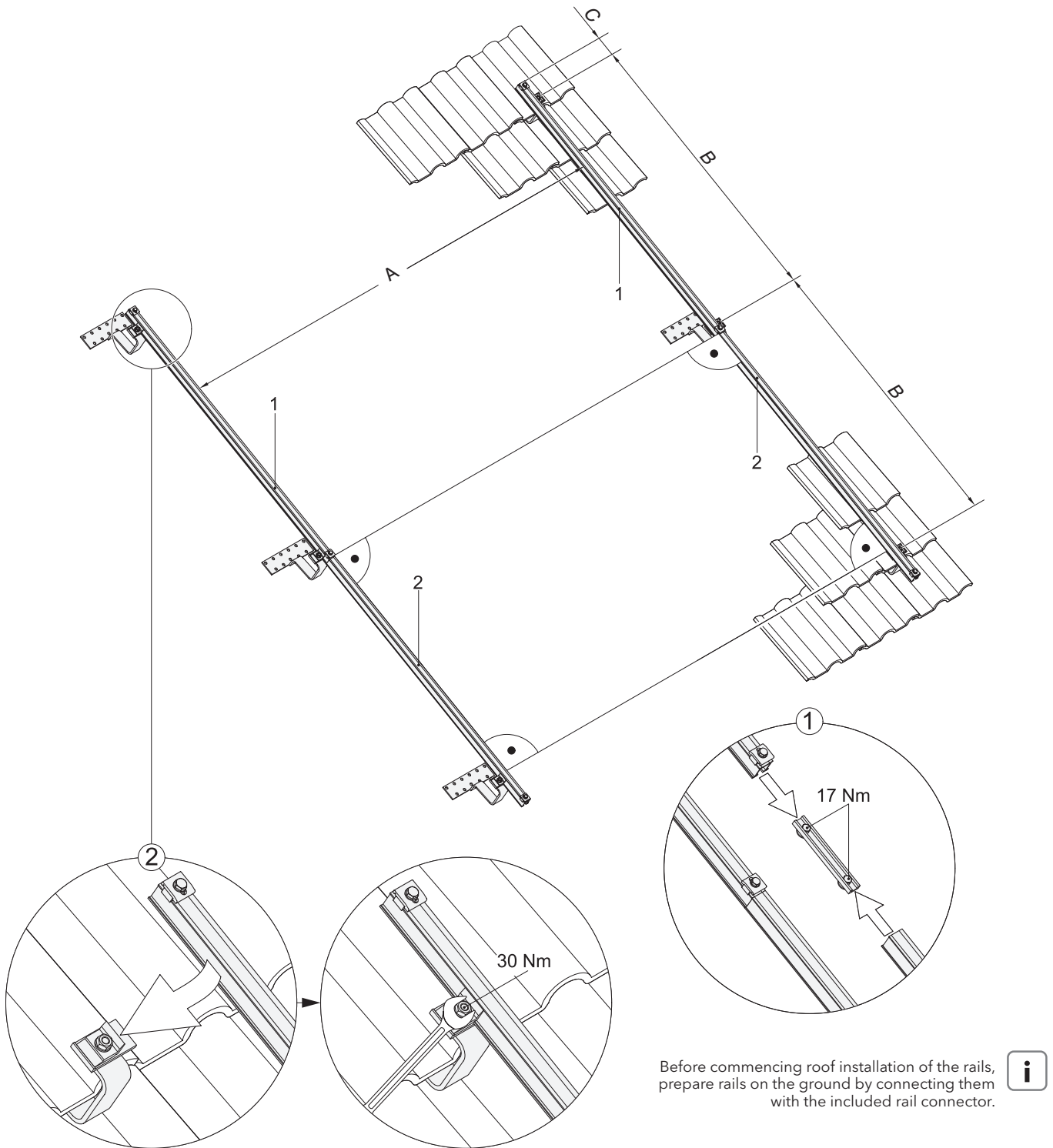

Figure 6 Correct fixing of roof bracket type P Stv to rafter

## 2.3 Supporting Rail Installation



Before commencing roof installation of the rails, prepare rails on the ground by connecting them with the included rail connector. 

Figure 8 Overview of rail installation (upper image; collector clamps are pre-assembled).  
**1** supporting rail "1" fixed with two roof brackets and holding two collector clamps  
**2** supporting rail "2" fixed with rail connector to upper rail and one roof bracket; rail "2" holds one collector clamp.

Table 3 Section	Distance (mm)
A	min. 1500
B	900 - 1200
C	20 - 200

## 2.4 Collector Installation



Mount uppermost collector first!

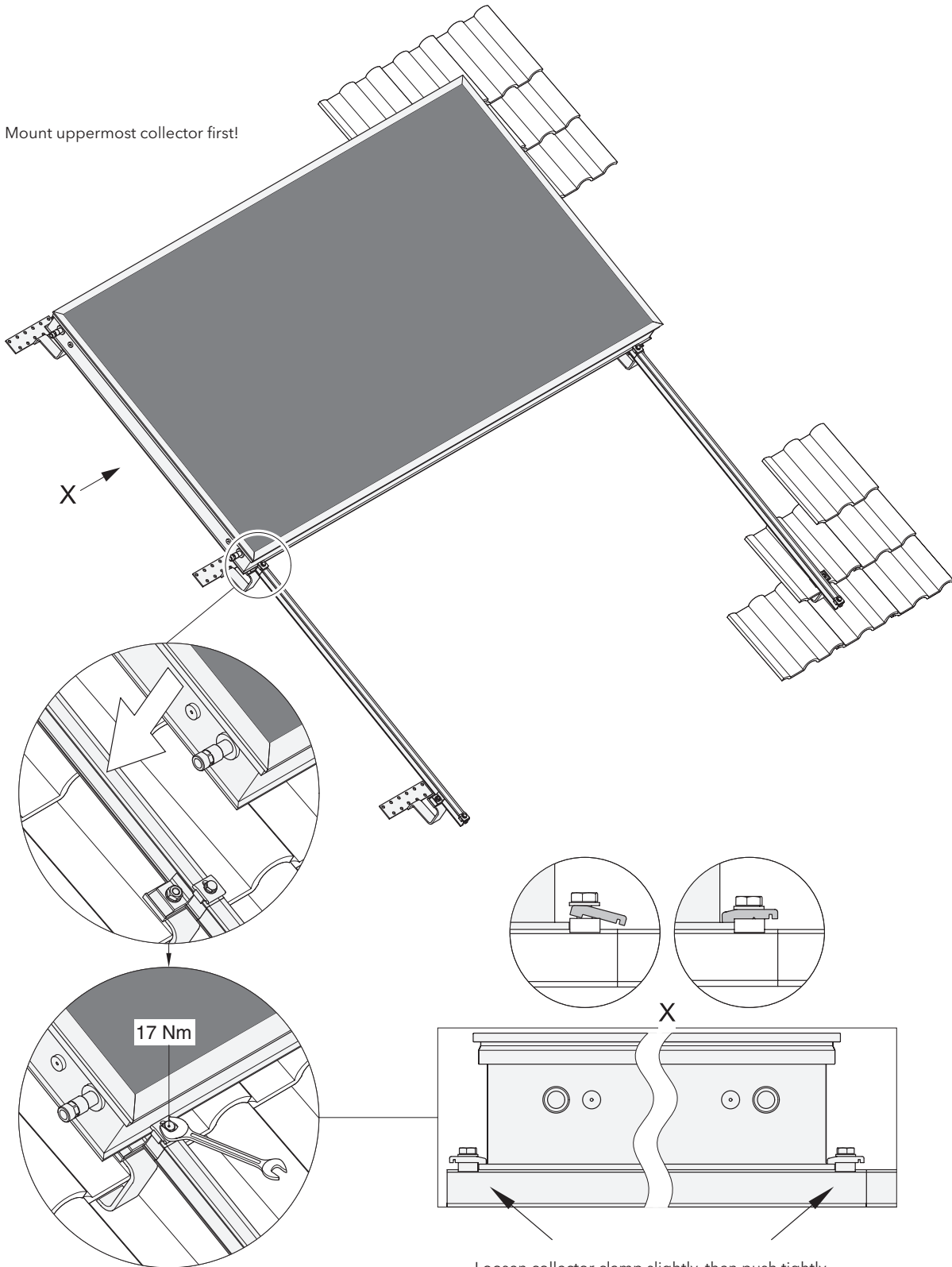

Figure 9 Installation of first (uppermost) collector

Loosen collector clamp slightly, then push tightly against collector and tighten (17 Nm).  
Badly positioned collectors can lead to insufficient fixation!



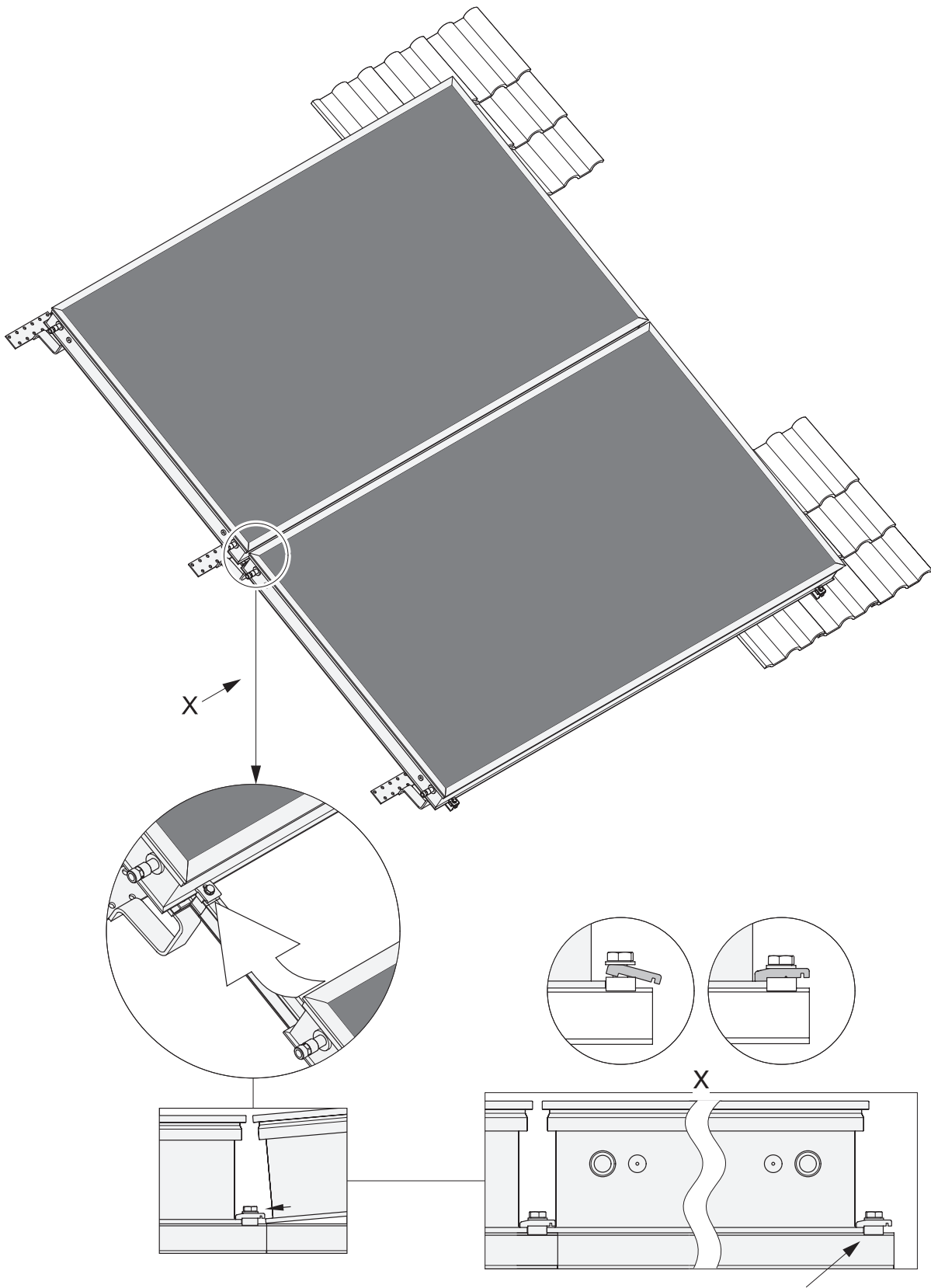

Figure 10 Installation of the following collectors

Loosen collector clamp slightly, then push tightly against collector and tighten screw (17 Nm). Badly positioned collectors can lead to insufficient fixation!



### 3. Vertical Installation

#### 3.1 Scope of Supply

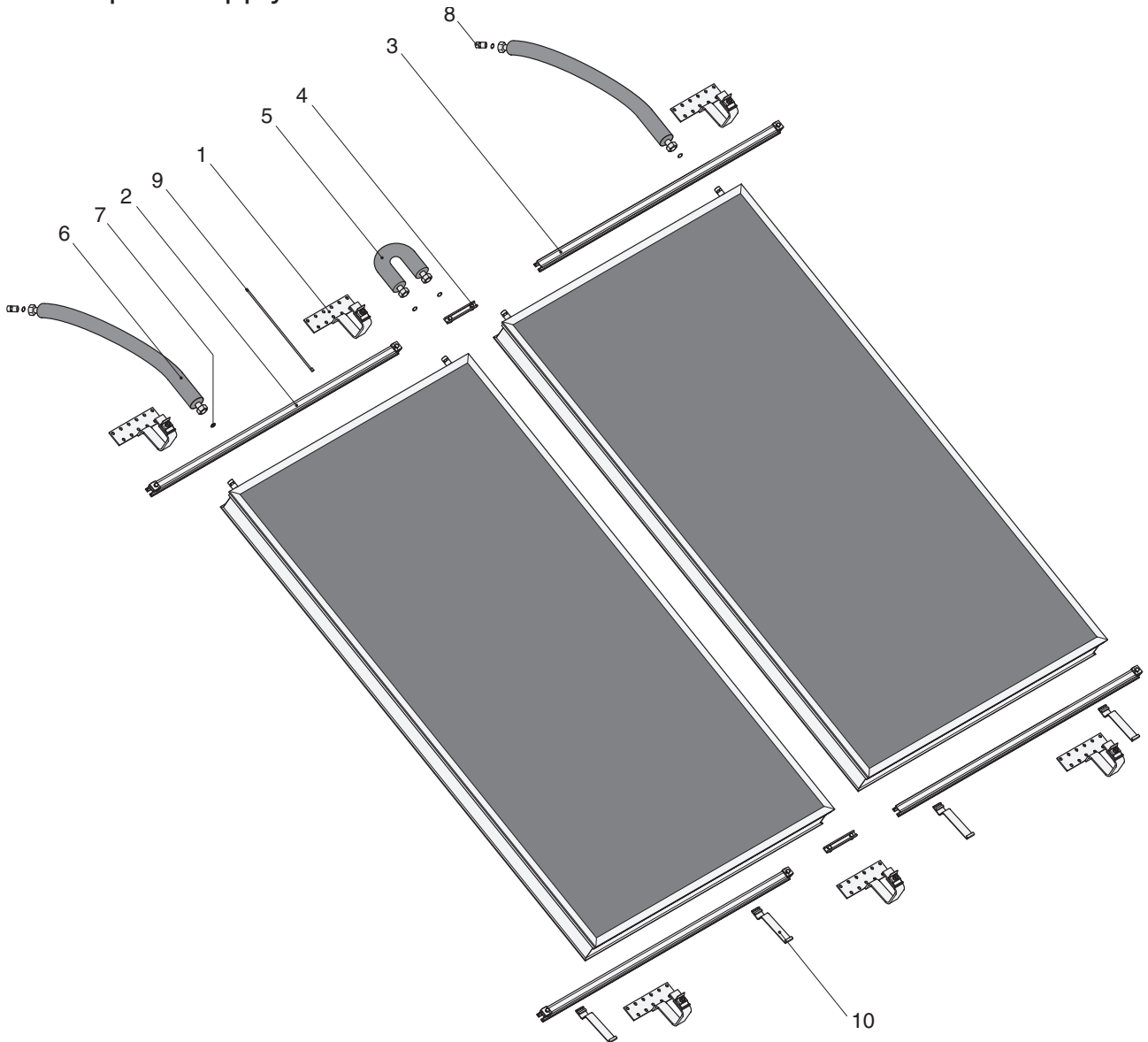

Figure 11 Basic Set for on-roof installation (collectors are not included in delivery)

Table 4 Figure no.	Components: Basic Set for On-Roof Installation	Quantity
1	Roof brackets <sup>1</sup>	(6) <sup>2</sup>
2	Collector supporting rail 1202 mm, incl. 2 collector clamps	2
3	Collector supporting rail 1168 mm, incl. 1 collector rail	2
4	Collector supporting rail connector	2
5	Collector interconnection hose, 250 mm length	1
6	Collector connection hose for solar circuit, 900 mm length	2
7	Gasket ½"	6
8	Adapter fitting ½" - 18 mm	2
9	Wire strap	1
10	Collector holder	4

<sup>1</sup> Not included in set; choose according to roofing type. <sup>2</sup> Required number depends on structural load calculation.

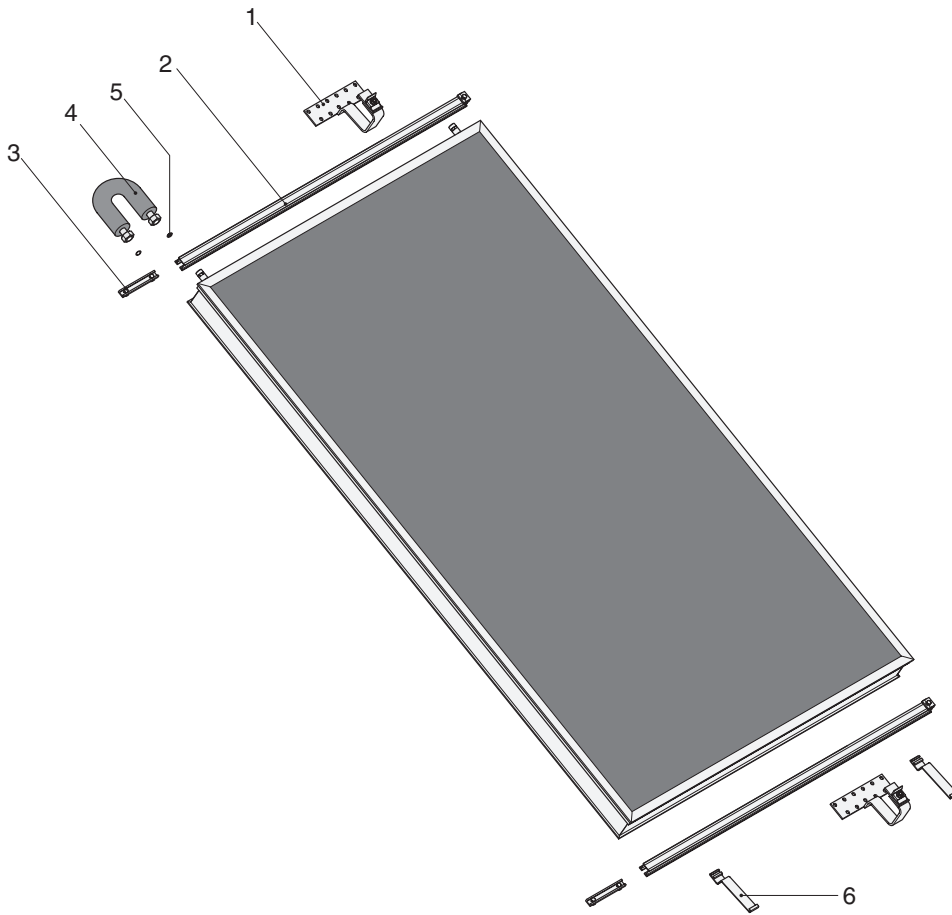

Figure 12 Extension Set for on-roof installation (collector is not included in delivery)

Table 5 Figure no.	Components: Extension Set for On-Roof Installation	Amount
1	Roof brackets <sup>1</sup>	(2) <sup>2</sup>
2	Collector supporting rail 1168 mm, incl. 1 collector clamp	2
3	Collector interconnection rail connector	2
4	Collector connecting hose, 250 mm length	1
5	Gasket ½"	2
6	Collector holder	2

<sup>1</sup> Not included in set; choose according to roofing type. <sup>2</sup> Required number depends on structural load calculation.

### 3.2 Installation of the Roof-Brackets

**i** The roof brackets shown in this manual are given as examples only. The actual type varies and depends on the roofing. For more information refer to the installation instructions included with the roof brackets.

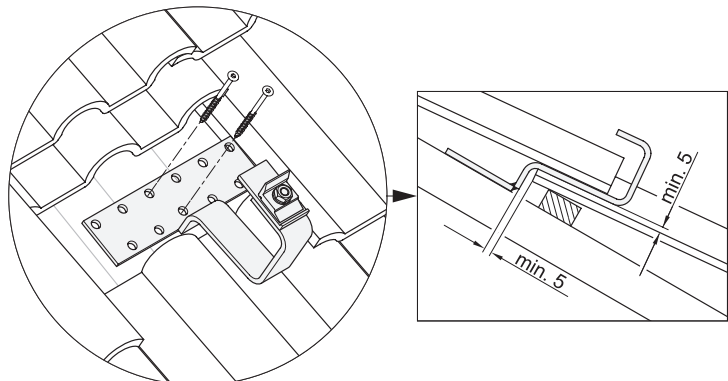

Figure 13 Correct fixing of roof bracket type P Stv to rafter

### 3.3 Supporting Rail Installation

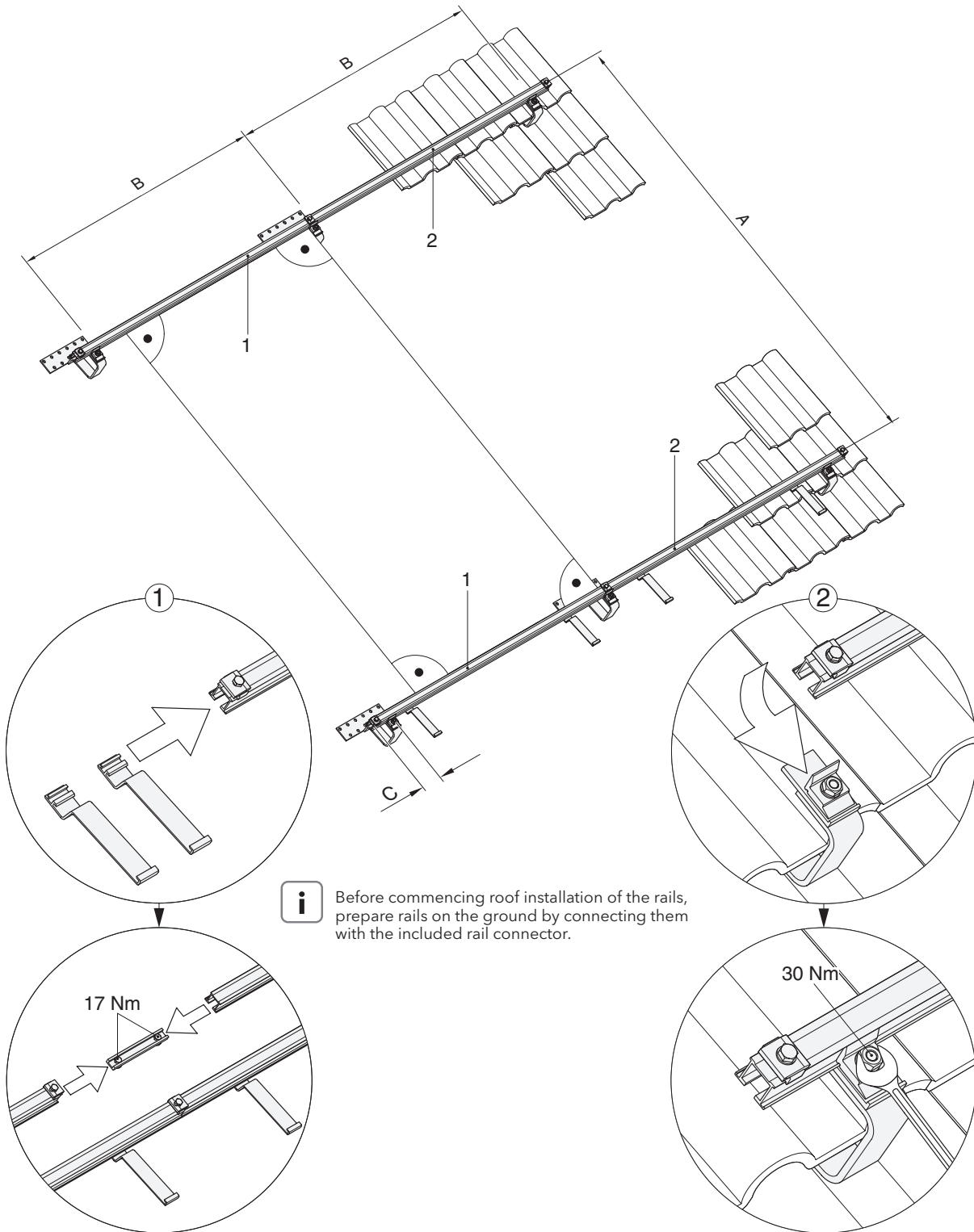

Figure 14 Overview of rail installation (upper image; collector clamps are pre-assembled).

1 supporting rail "1" fixed with two roof brackets and holding two collector clamps

2 supporting rail "2" fixed with rail connector to upper rail and one roof bracket; rail "2" holds one collector clamp.

Table 6 Section	Distance (mm)
A	min. 1500
B	900 - 1200
C	20 - 200

### 3.4 Collector Installation

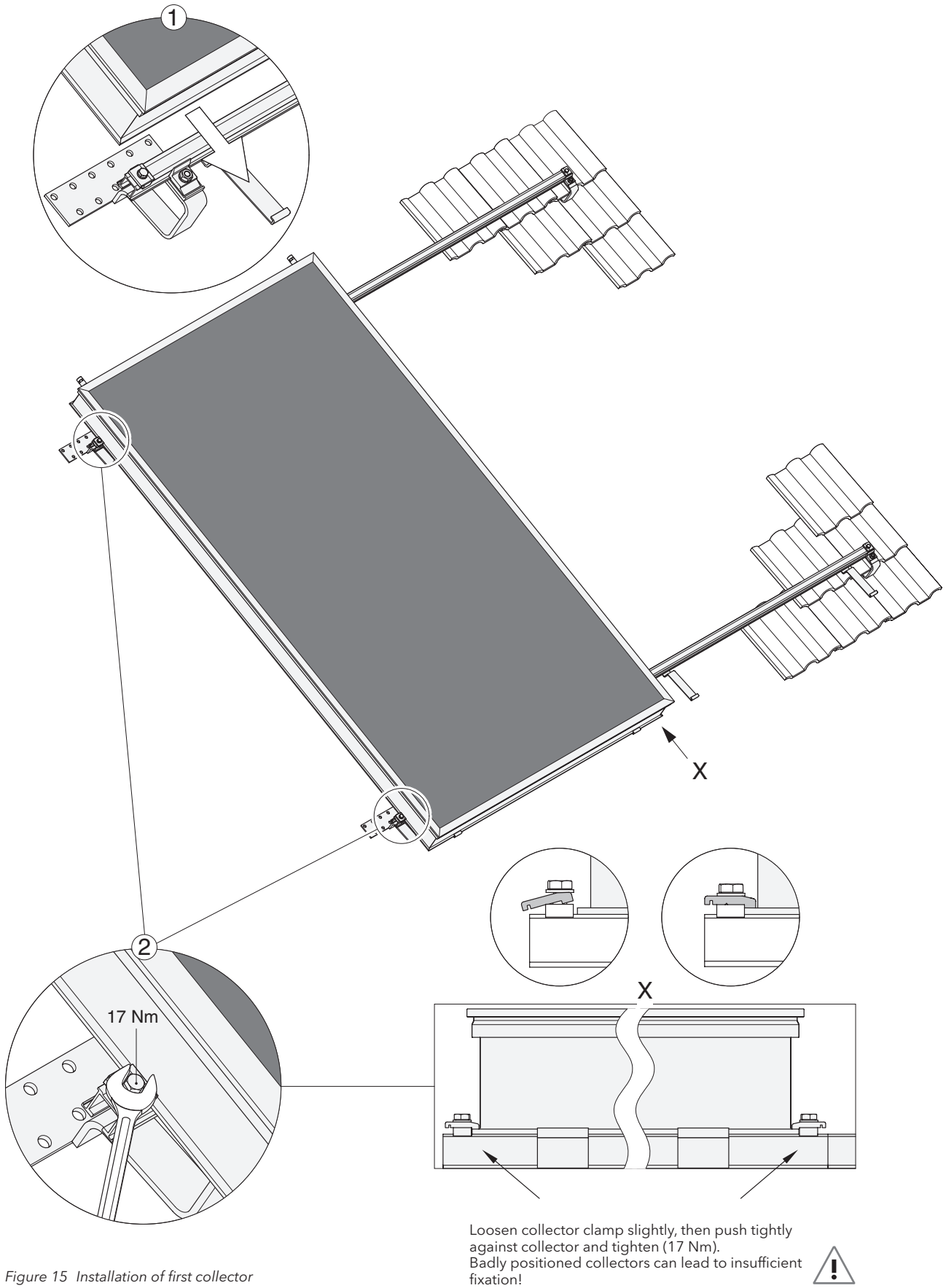

Figure 15 Installation of first collector

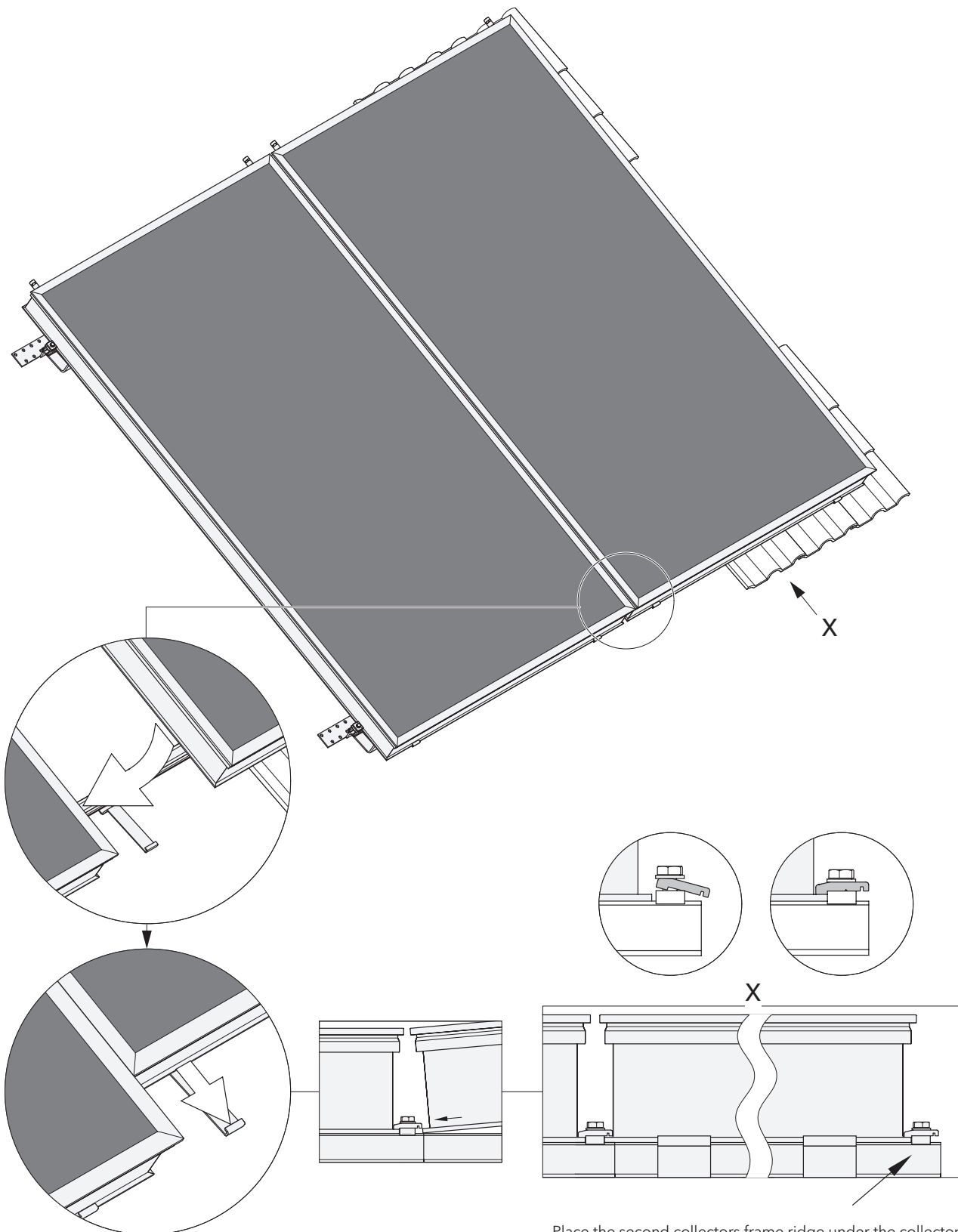

Figure 16 Installation of following collectors

Place the second collectors frame ridge under the collector clamps on the side of the first collector. Slightly loosen on other side, push towards collector and fasten the collector clamps (17 Nm). Wrong or badly positioned collectors can lead to an insufficient fixation!



## 4. Sensor Installation

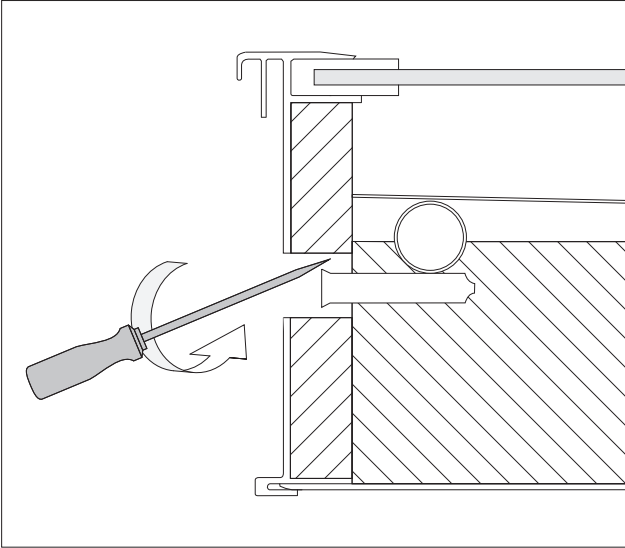

Figure 17 Remove rubber plug from frame. If necessary use screw driver to uncover sensor sleeve.

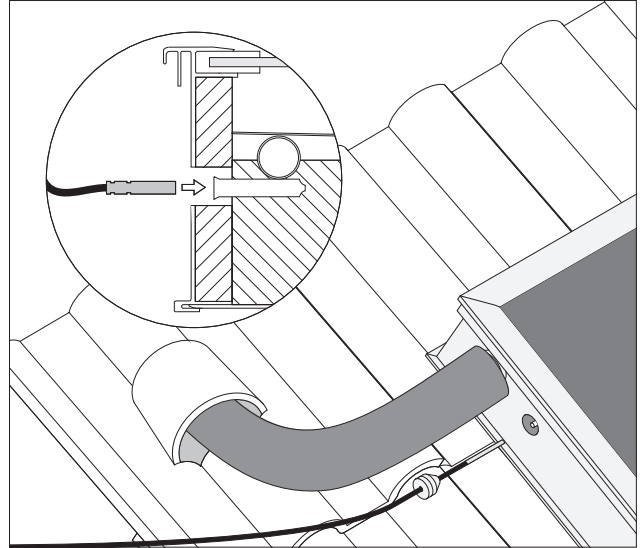
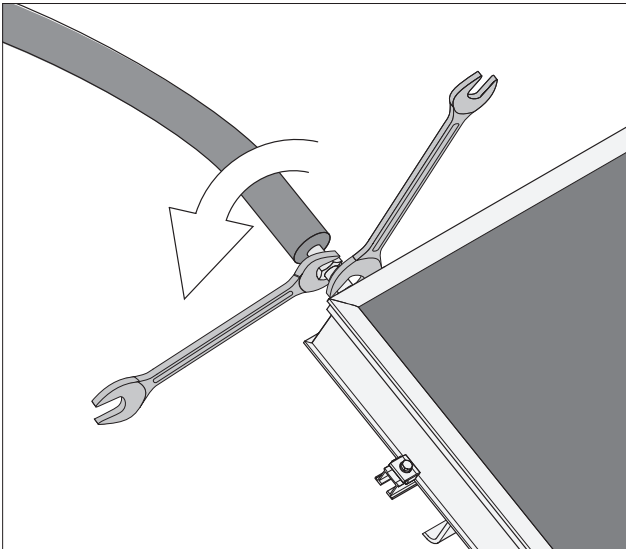



Figure 18 Pull sensor through rubber plug and insert sensor top into sensor sleeve. Screw in rubber plug again.

## 5. Collector Connections



 Figure 19 Use counter force to support collector interconnection hose when tightening to protect connection and hose against damage.

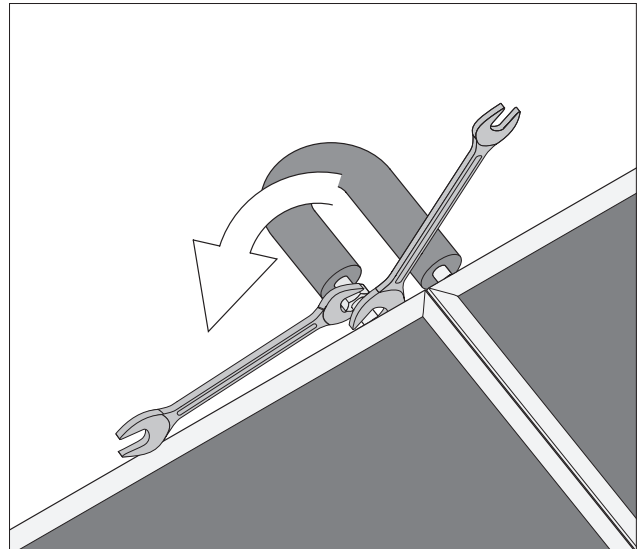



Figure 20 Use counter force to support collector interconnection hose when tightening to protect connection and hose against damage. 

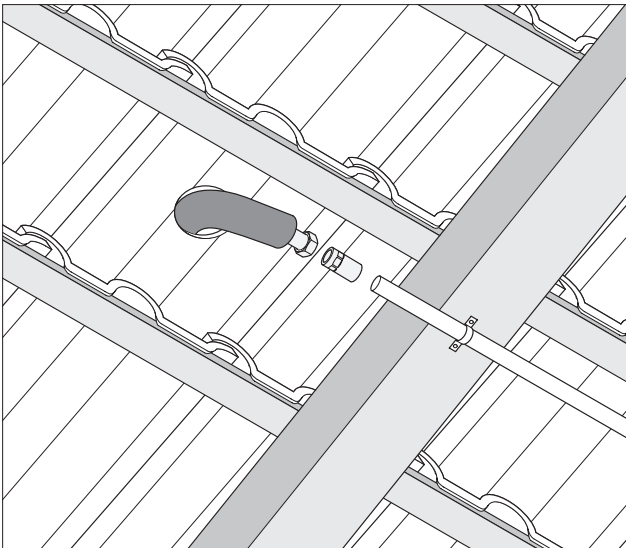

Figure 21 Connect the collector interconnection hose to the solar circuit inside the roof via adapter fitting  $\frac{1}{2}$ "-18 mm.

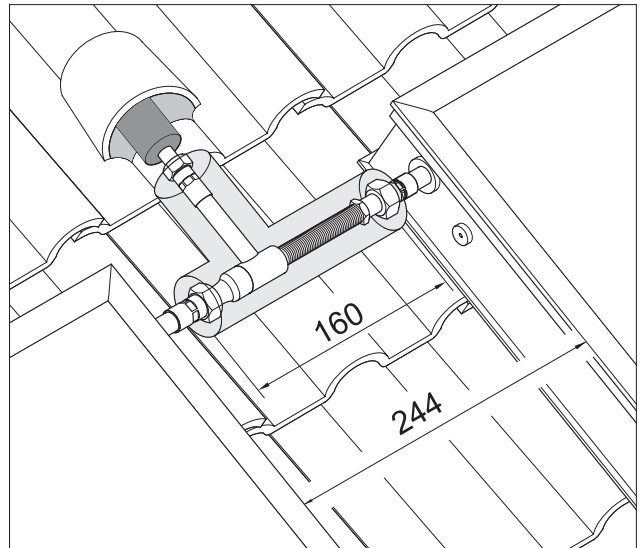

Figure 22 2 collectors installed on-roof, horizontal and next to each other can be connected with a special connection set (part no. 190 202 30).

## 6. Accessories



Figure 23 Collector handles for an easy transport (part no. 188 005 02).



Figure 24 Protection of sensor cable against birds (part no. 192 040 09 for black collectors, part no. 192 040 10 for aluminium coloured collectors).

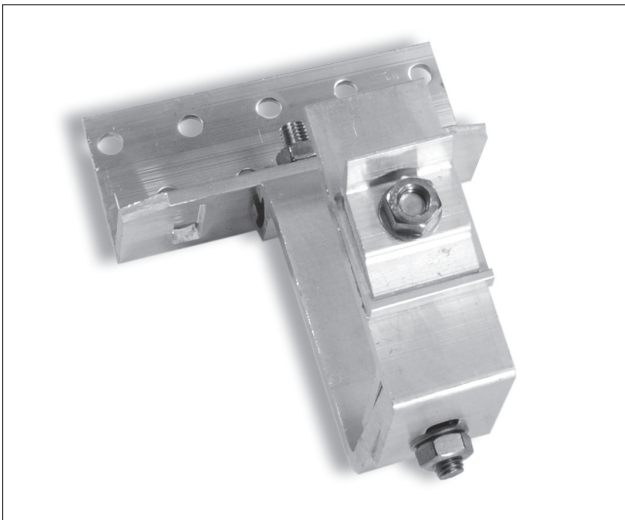

Figure 25 Height adjustable roof brackets P Alu Hv Top for flat clay tiles for equalising uneven roofs (basic set includes 6 pieces, part no. 192 030 32).



Figure 26 Roof brackets BS Stv KF Top for slate and plane tiles for equalising uneven roofs (basic set incl. 6 items, part no. 192 030 25).



Figure 27 EURO connection set, 2x horizontal (part no. 190 202 30) for connecting two collectors next to each other, horizontal.