



Barilla Solar Collector F22 AR



Figure 1 Barilla F22 AR

Product Features

Powerful

- Collector cover with sandy sunarc® anti-reflection glass for 96% light transmission
- Laser fused aluminum absorber for optimized heat transfer
- 60 mm back-side insulation

Durable High Quality Materials

- Anodized aluminum frame in silver or black
- Solid aluminium back
- Full-surface aluminium absorber sheet with copper pipe register
- Temperature resistant mineral wool with low binder content, heat conduction group 040

Sophisticated Construction Details

- Seamless all-around side insulation
- Long lasting and safe flat sealing connections
- UV resistant EPDM glass sealing with vulcanized corner joints

Flexible Racking Options

- Suitable for on-roof, roof-integrated and flat-roof (free standing) installation
- Serial connection of up to 5 collectors possible

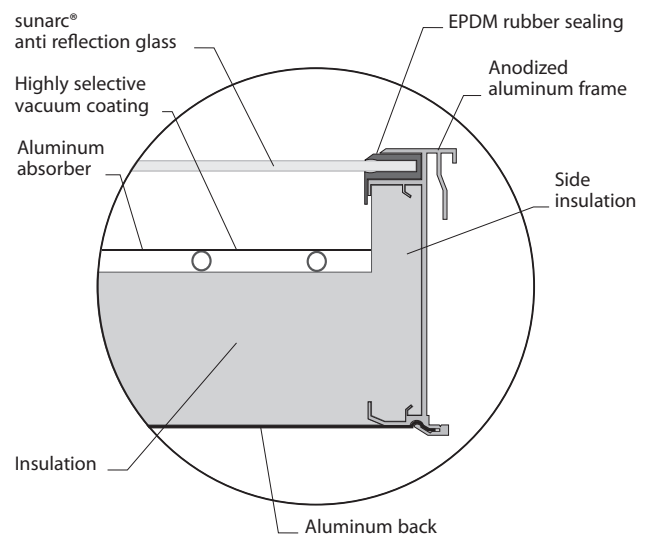

Figure 2 Collector cross section

1. Technical Data

Table 1 Features	Barilla F22 AR
Total area/aperture area (acc. to EN 12975)	2.24 m ² / 2.01 m ²
Dimensions (L x D x H)	1930 mm x 1160 mm x 110 mm
Collector efficiency (acc. to EN 12975)	$\eta_0 = 83.1\%$; $a_1 = 3.44 \text{ W/m}^2$; $a_2 = 0.0176 \text{ W/m}^2\text{K}^2$
Incident angle modifier (50°)	$k_{\text{theta}}(50^\circ) = 92\%$; $K_{\text{diff}} = 84\%$
Annual collector yield (ITW 5 m ²)	499 kWh/m ²
Collector encasing	Silver or black anodized aluminum frame, aluminum back sheet, stone wool insulation WLG 040 for back side and frame (melting point > 1000 °C)
Specific heat capacity	4.6 kJ/m ² K
Glass cover and light transmission	4 mm solar safety glass with sunarc® anti reflection surface; $\tau = 96\%$
Absorber	Pipe register absorber: aluminum heat conductor sheet and 12 closely spaced copper pipes, laser fused
Absorber coating	Highly selective vacuum coating, $\alpha = 95\%$, $\epsilon = 5\%$
Absorber content	1.24 litres
Heat carrier	Barilla Solar Heat Transfer Fluid
Operational pressure	max. 10 bar
Stagnation temperature (acc. to EN 12975)	208 °C
Solar sensor	Receptacle, 6 mm internal diameter
Collector connections	½" M - threaded connection
Certificate/mark	CE-Mark, tests acc. to EN 12975, prerequisites for SolarKeymark are met
Allowable pressure/suction forces	

2. Planning Notes

Pressure drop [mbar]

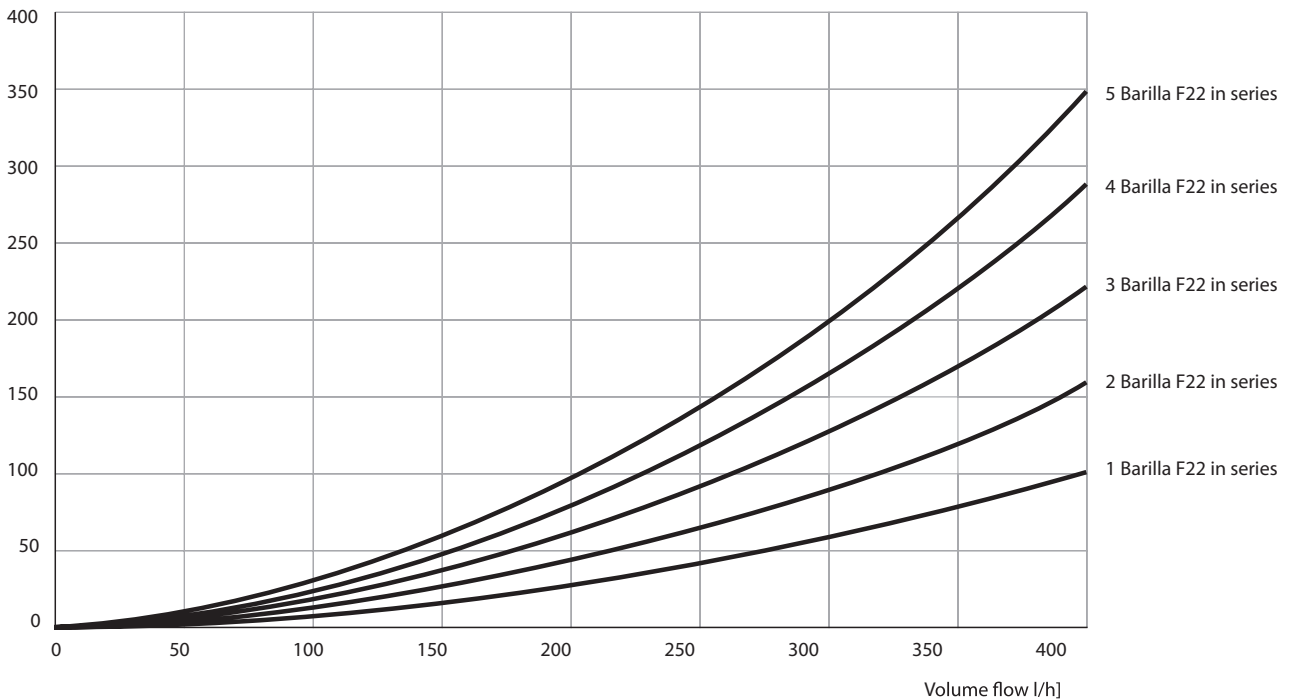

Figure 3 Pressure loss curves for several collectors connected in series, depending on volume flow. Heat carrier: 40% Glycol / 60% Water at 30 °C.

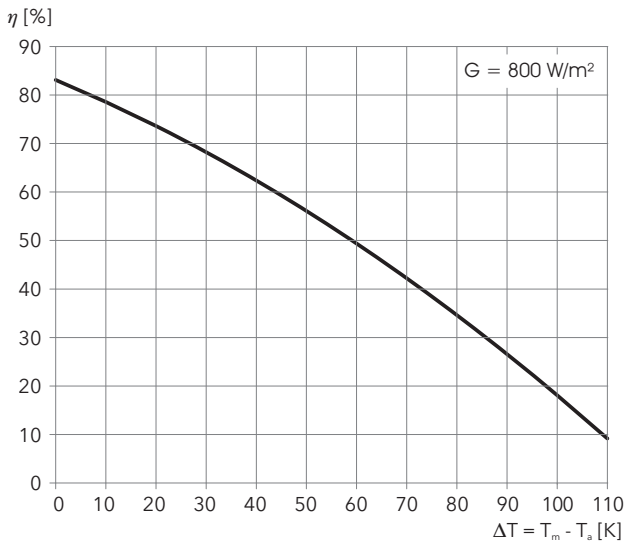

Figure 4 Collector characteristics acc. to EN 12975

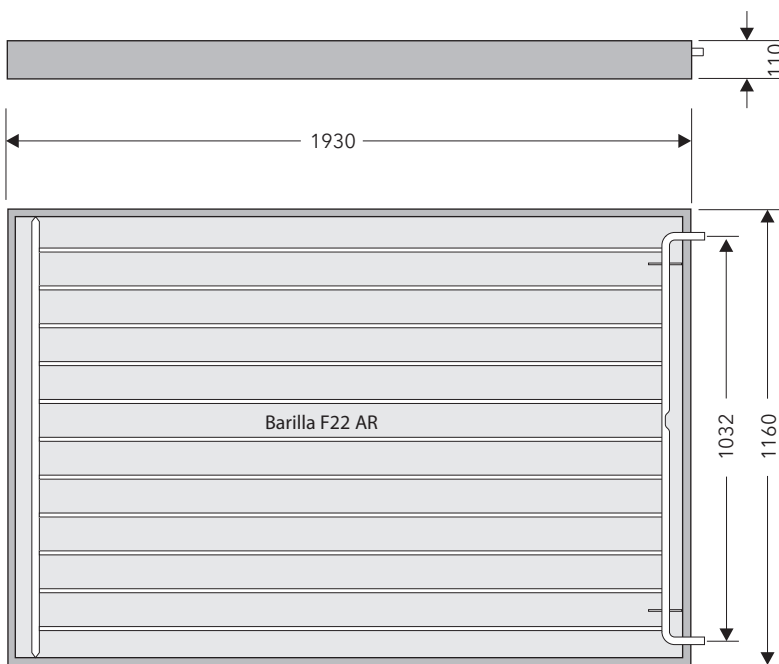

Figure 5 Dimensions (mm)

2.1 Snow and Wind Loads

Comply with local regulations and norms related to snow and wind loads (within the EU to EN 1991-1-4 (wind actions) and EN 1991-1-3 (snow loads). The standard in-roof system originally was designed for the following conditions: inland continental Europe up to 800 m ASL, unexposed location, maximum building height of 20 m, all wind zones. Please contact our technical department for information about other cases.

Table 2 Dimensioning Examples for Snow/Wind Load Zones 1-2 ¹				
Building height (m)	Altitude (m)	On-roof installation (no. of roof brackets per collector) ²	Free standing, ballast (kg/m ² total collector area)	
			Horizontal setup	Vertical setup
10	400	4	140	195
10	800	6	140	195
10-20	400	4	185	260
10-20	800	6	185	260

¹ 45° inclination, installation in edge and corner areas of roofs not considered; wind speed $V_{ref} \leq 25$ m/s, wind pressure at 10 m above ground $q_{ref} \leq 0.39$ (kN/m²)

² Roof Bracket for Flat Clay Tiles or similar; ridge distance or distance to snow barrier above < 1 m; roof bracket quantities are guide values - round acc. to field size and individual situation.

2.2 Free Standing Setup and Mutual Shadowing

The following table applies to a shadowing angle β of 25°. Depending on the geographical location the lower collector sections may therefore be affected by mutual shadowing during winter months.

Tab. 3 Shadowing Distance						
Distances in m (s. Abb. 5)	Collector inclination α					
	Horizontal setup			Vertical setup		
	35°	45°	50°	37°	45°	50°
A	1.42	1.76	1.91	2.49	2.93	3.17
B	0.95	0.82	0.75	1.54	1.36	1.24
C	3.32	3.4	3.41	5.57	5.65	5.65

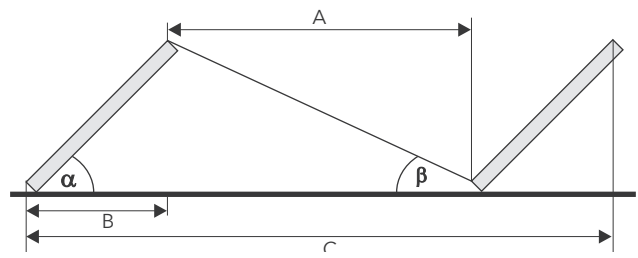

Figure 6 Shadowing distances of collectors mounted one behind the other with collector inclination α and shadowing angle β

2.3 Connection Options

Valid for a volume flow $v = 35 \text{ l/m}^2\text{h}$ (High-Flow)

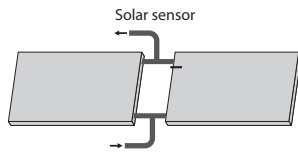

Figure 7 Parallel connection of 2 x horizontal Barilla F22. A special extension set for on-roof mounting (prod. no. 190 202 40) and a special connection set (prod. no. 190 202 30) are available.

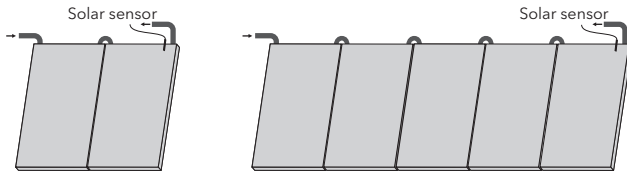

Figure 8 Serial connection of vertically mounted collectors (serial connection of max. 5 x Barilla F22)

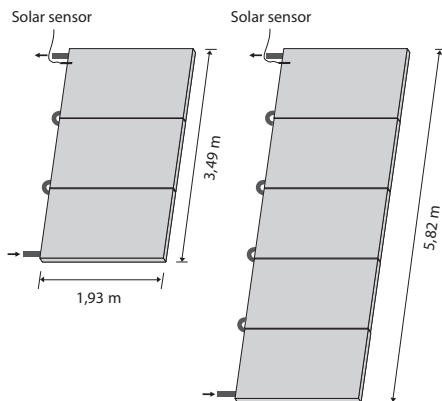

Figure 9 Serial connection of horizontally installed collectors (serial connection of max. 5 x Barilla F22)

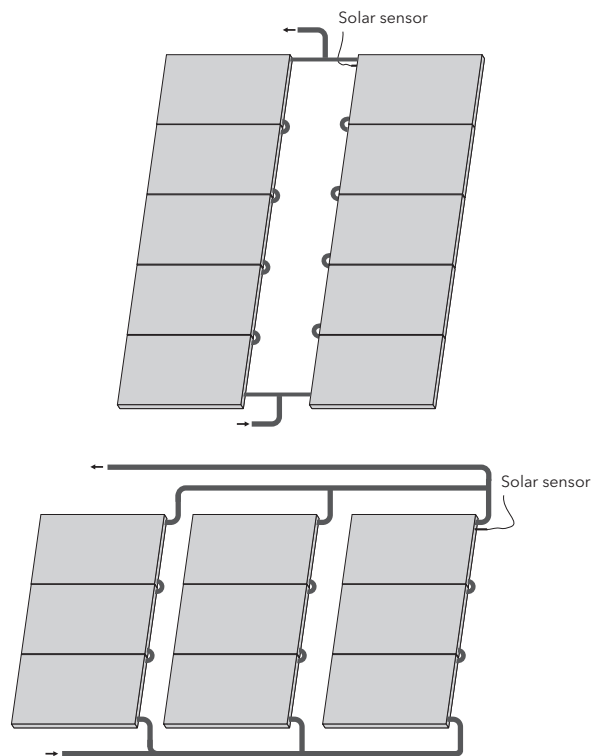

Figure 10 Combination of serial and parallel connections of horizontally mounted collectors

2.4 Accessories

Table 4 Accessories	Product No.
Marten protection for sensor cable	192 040 09
Collector carrying handles	188 005 02
Connection set for side-by-side horizontal installation	190 202 30